

BITHERMOSTATIC BIMETALIC STEAM TRAP P215Ti (DN 15 - 25 / DN 1/2" - 1")

General Description

Bi-Thermostatic bimetallic steam trap, with corrosion resistant regulator unaffected by waterhammer and superheated steam. Balanced pressure valve. Independent seat and shutter, and external adjustment device while running for temperature and flow discharge.

The fact that both, valve and seat, be independent and located in the low flow discharge area, reduces erosion and extends the life of the trap. The condensate discharge is controlled by bimetallic thermostat, continuously adjusting to changes of condensate flow. Automatic air venting. Installation in any position. The independence of the valve and seat reduces dramatically the costs of its spare parts, joined to the fact that it has an external adjustment device while running, makes an extremely low maintenance cost steam trap.

Operation

During the start-up, the condensate is cold and the bimetals are flat. When the temperature starts to rise the bimetals will expand producing the progressive closure of the valve. In this way the steam trap is able to adjust itself to changing conditions because if the pressure rises, the higher pressure acts on the valve but at the same time the higher temperature will act on the bimetals. Its quick automatic air venting prevents air binding. The valve is placed on the upper stream far from the flash steam zone, this avoids erosion and waste, contributes to a long effective life and reduces maintenance costs.

Operating conditions

Max. operating pressure:	215 bar
Max. differential pressure:	215 bar
Max. Temperature:	550 °C

Conexiones

- Butt Weld: 1/2", 3/4", 1".
- Socket Weld: 1/2", 3/4", 1".
- Flange: DIN PN 100/150/250, DN 15, 20, 25.
ANSI 900/1500#, DN 1/2", 3/4", 1".
- Other connections upon request.

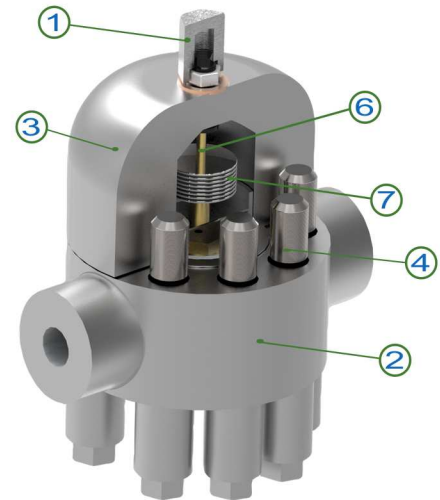

Materials

1 Cover	Alloy F1550
2 Body	Alloy A387 GR12/13CrMo 4-5
3 Top cap	S. steel AISI 303
4 Bolt	Alloy F1550
5 Seat	S. steel AISI 420(*)
6 Valve	S. Steel AISI 440B(*)
7 Bimetals	Alloy. 38/7NiCr & 19/7NiCr
8 Nuts	Alloy F1550

(*) Coated by Titanium Nitride (TiN).

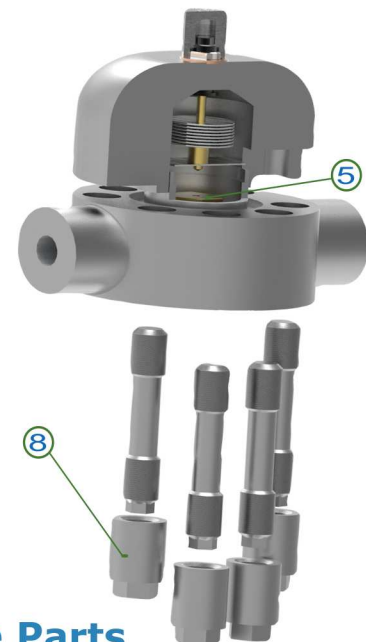

Spare Parts

- Seat
- Valve
- Gasket set

STEAM TRAP P215Ti

Dimensions

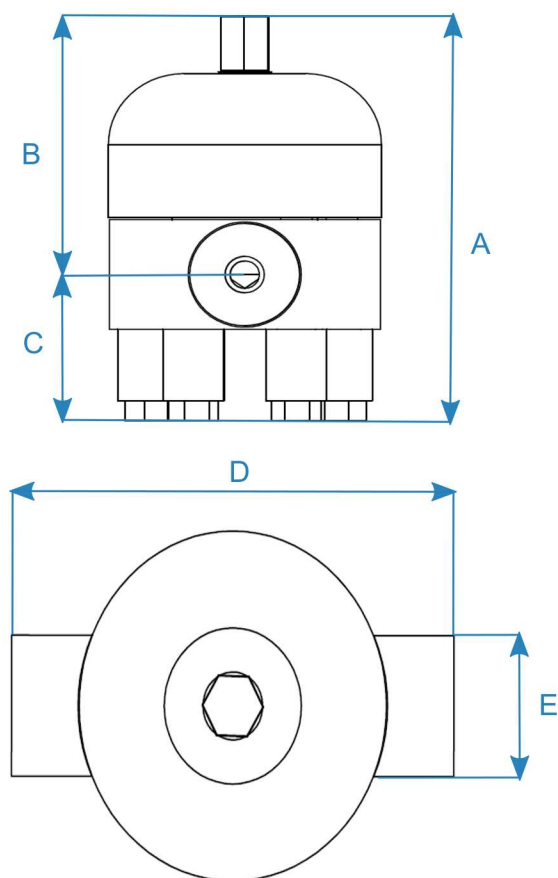

A (mm)	232
B (mm)	152
C (mm)	80
D (mm)	200
E (mm)	57.5

Approximate weight (without flanges): 10 Kg

Capacity Curve

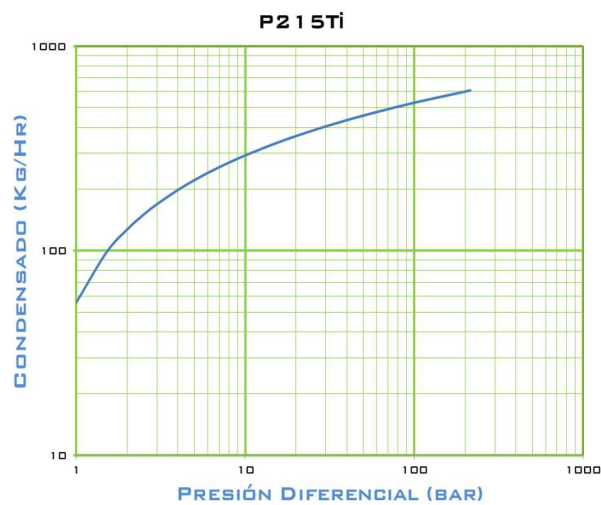

Cold water (Start-up) capacity will be 2.5 higher.

External adjustment

With its external adjustment device, the user can easily modify the conditions of evacuation of condensate without interrupting the steam trap service. To do this, simply remove the top cap (24 mm wrench), loosen the lock nut (17mm wrench) and turn as necessary the adjustment screw (8 mm wrench), up to get the required condensate flow or temperature. Once adjusted, fix the safety nut with soft pressure and place back the top cap, fix tightly to achieve the total sealing. If sealing problems through the gasket are observed, replace it with an original new one.



Produced in accordance with Article 4.3 del PED - European Pressure Equipment Directive - PED 2014/68/EU.

Technical modification reserved. Copyright BiTherm 2020.

For more information please visit web www.bitherm-sistemas.com or contact your Bitherm's distributor.